

**High Productivity Cooking  
 Electric Rectangular Braising Pan, 170lt,  
 Hygienic Profile, Freestanding with Tap**

ITEM # \_\_\_\_\_

MODEL # \_\_\_\_\_

NAME # \_\_\_\_\_

SIS # \_\_\_\_\_

AIA # \_\_\_\_\_

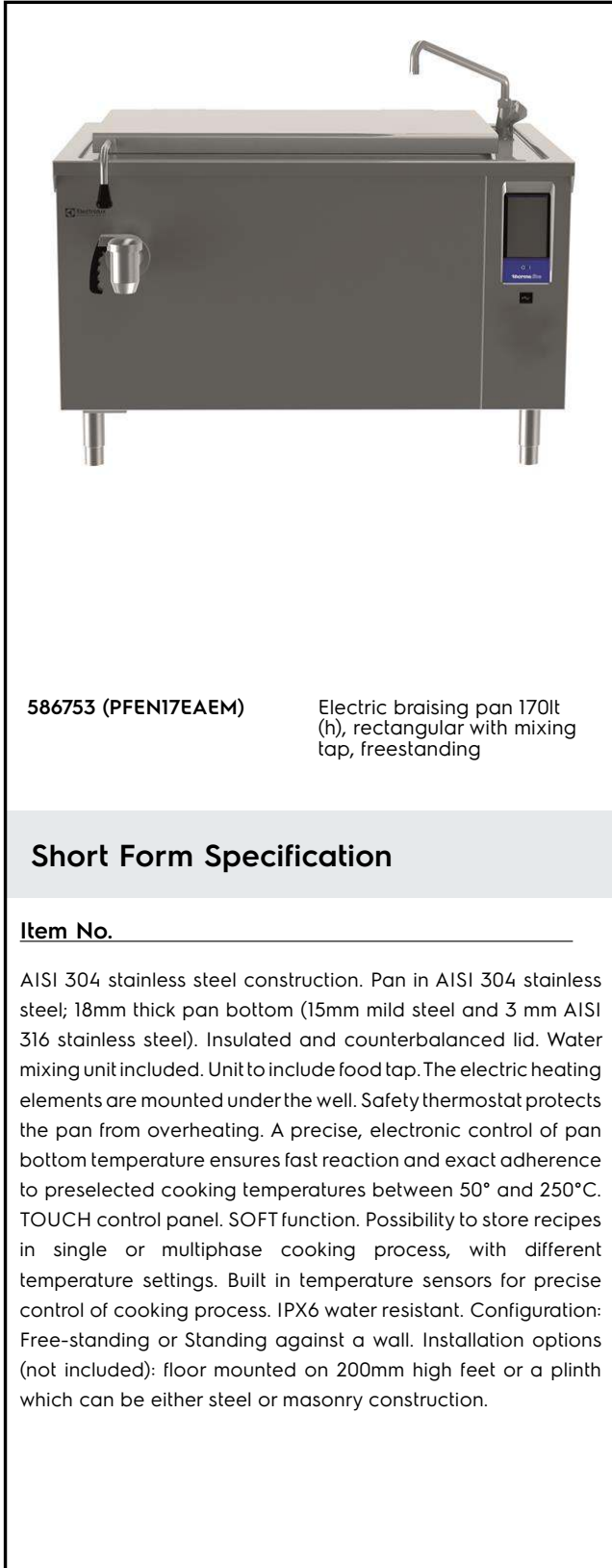

**586753 (PFEN17EAEM)** Electric braising pan 170lt (h), rectangular with mixing tap, freestanding

### Short Form Specification

**Item No.** \_\_\_\_\_

AISI 304 stainless steel construction. Pan in AISI 304 stainless steel; 18mm thick pan bottom (15mm mild steel and 3 mm AISI 316 stainless steel). Insulated and counterbalanced lid. Water mixing unit included. Unit to include food tap. The electric heating elements are mounted under the well. Safety thermostat protects the pan from overheating. A precise, electronic control of pan bottom temperature ensures fast reaction and exact adherence to preselected cooking temperatures between 50° and 250°C. TOUCH control panel. SOFT function. Possibility to store recipes in single or multiphase cooking process, with different temperature settings. Built in temperature sensors for precise control of cooking process. IPX6 water resistant. Configuration: Free-standing or Standing against a wall. Installation options (not included): floor mounted on 200mm high feet or a plinth which can be either steel or masonry construction.

### Main Features

- Multifunctional cooking appliance used for roasting, pot-roasting, braising, simmering, boiling and steaming.
- Square inner kettle allows working with stacked Gastronorm containers, which facilitate loading and unloading operations.
- Easy to clean cooking surface due to large-radius edges and corners.
- Thermoblock heating system for optimal temperature distribution and high temperature stability.
- Pan bottom with two individually adjustable heating zones, each with a temperature sensor.
- Large capacity food tap enables safe and effortless discharging of contents.
- Discharge tap is very easy to disassemble and clean.
- Temperature sensors provides efficient temperature control: the power is supplied as and when required to keep the set temperature value without exceeding it.
- IPX6 water resistant.
- Optimum heat distribution in the food provides best cooking results in terms of taste, colour and consistency and in terms of vitamin preserving.
- Overnight cooking: saving electricity and time.
- Built in temperature sensor to precisely control the cooking process.
- No overshooting of cooking temperatures, fast reaction.
- USB connection to easily update the software, upload/download recipes and download HACCP data.

### Construction

- External panelling and internal frame made of 1.4301 (AISI 304) stainless steel.
- Multipurpose non-stick cooking surface in 18 mm thick compound: 3 mm shot-blasted 1.4404 (AISI 316L) stainless steel surface, seamlessly welded to the mild steel bottom.
- Double-lined insulated lid in 1.4301 (AISI 304) stainless steel mounted on the cross beam of the unit, counterbalanced by a hinge that remains open in all positions.
- 15 mm thick heating layer concealed below the entire pan bottom, to provide high thermal diffusion and heat storage properties.
- 2" diameter discharge tap for rapid emptying of the well.
- Water mixing tap is available as optional accessory to make water filling and pan cleaning easier.

**APPROVAL:** \_\_\_\_\_

- Heatproof handle with non-slip surface.
- Front-mounted inclined led "TOUCH" control panel with recessed deep drawn casing, features self-explanatory display functions which guide operator throughout the cooking process: simultaneous display of actual and set temperature as well as set cooking time and remaining cooking time; real time clock; "SOFT" control for gentle heating up for delicate food; 9 power simmering levels from gentle to heavy boiling; timer for deferred start; error display for quick troubleshooting.
- Minimised presence of narrow gaps for easier cleaning of the sides to meet the highest hygiene standards.
- Possibility to store recipes in single or multiphase cooking process, with different temperature settings.
- "Boiling" or "Braising" mode functions.
- Can be prearranged for energy optimisation or external surveillance systems (optional).
- 98% recyclable by weight; packaging material free of toxic substances.
- Lateral surface of the vessel in DIN 1.4301/AISI 304.
- GuideYou Panel - activated by the user via settings - to easily follow the multiphase recipes, granting a proper and controlled cooking and a better appliance optimization. CHAR(13)CHAR(10)The system will provide maintenance reminders, in line with ESSENTI
- Highly-visible and bright led TOUCH control panel features user-friendly icons and intuitive self-explanatory command options. Display visualizes: CHAR(13)CHAR(10) - Actual and set temperature CHAR(13)CHAR(10) - Set and remaining cooking time CHAR(13)CHAR(

### User Interface & Data Management

- Connectivity ready for real time access to connected appliances from remote and data monitoring (requires optional accessory - contact the Company for more details).

### Sustainability

- High-quality thermal insulation of the pan saves energy and keeps operating ambient temperature low.

### Optional Accessories

- Strainer for dumplings for all tilting & stationary braising and pressure braising pans (except 80lt) and for all stationary rectangular and 100lt round boiling pans PNC 910053
- Scraper for dumpling strainer for boiling and braising pans PNC 910058
- Suspension frame GN1/1 for rectangular boiling and braising pans PNC 910191

- Base plate 1/1 GN for braising pans PNC 910201
- - NOT TRANSLATED - PNC 910211
- Small perforated shovel for braising pans (PFEN/PUEN) PNC 911577
- Small shovel for braising pans (PFEN/PUEN) PNC 911578
- - NOT TRANSLATED - PNC 911579
- Perforated container with handles 1/1GN (height 200mm) for boiling and braising pans PNC 911673
- - NOT TRANSLATED - PNC 912468
- - NOT TRANSLATED - PNC 912469
- Power socket Schuko typ-23, 16A/230V, built-in version PNC 912470
- Power socket Swiss typ-23, 16A/230V, built-in version PNC 912471
- Power socket Swiss typ-23, 16A/380V, built-in version PNC 912472
- - NOT TRANSLATED - PNC 912473
- - NOT TRANSLATED - PNC 912474
- - NOT TRANSLATED - PNC 912475
- - NOT TRANSLATED - PNC 912476
- - NOT TRANSLATED - PNC 912477
- - NOT TRANSLATED - PNC 912478
- - NOT TRANSLATED - PNC 912485
- Connecting rail kit, 800mm PNC 912500
- Set of 4 feet for stationary units (height 200mm) - factory fitted PNC 912732
- Automatic water filling (hot and cold) for stationary units (width 700-1000mm): rectangular pressure boiling and braising pans - factory fitted PNC 912736
- Kit energy optimization and potential free contact - factory fitted PNC 912737
- Mainswitch 60A, 6mm<sup>2</sup> - factory fitted PNC 912740
- - NOT TRANSLATED - PNC 912783
- - NOT TRANSLATED - PNC 912784
- Connecting rail kit: modular 80 (on the left) to ProThermetic tilting (on the right), ProThermetic stationary (on the left) to ProThermetic (on the right) PNC 912971
- Connecting rail kit: modular 80 (on the right) to ProThermetic tilting (on the left), ProThermetic stationary (on the right) to ProThermetic (on the left) PNC 912972
- 1 basket 1/1 GN for 40lt pasta cooker, ProThermetic braising and pressure braising pans, GN compatible (to be combined with suspension frame) PNC 913134
- - NOT TRANSLATED - PNC 913358
- - NOT TRANSLATED - PNC 913390
- - NOT TRANSLATED - PNC 913391

- - NOT TRANSLATED - PNC 913414
- - NOT TRANSLATED - PNC 913415
- - NOT TRANSLATED - PNC 913431
- - NOT TRANSLATED - PNC 913432
- - NOT TRANSLATED - PNC 913479
- - NOT TRANSLATED - PNC 913480
- - NOT TRANSLATED - PNC 913491
- - NOT TRANSLATED - PNC 913492
- - NOT TRANSLATED - PNC 913577

**ACC\_CHEM**

- \*NOT TRANSLATED\* PNC 0S2292

Front

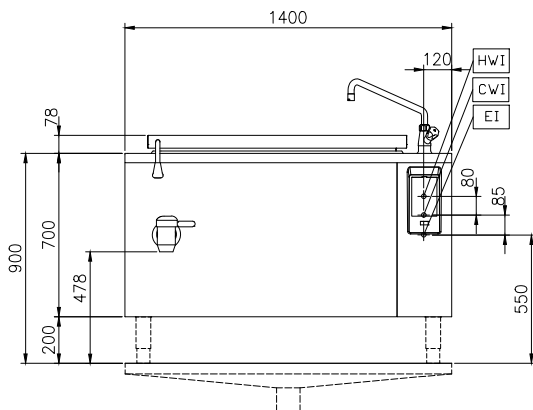

Side

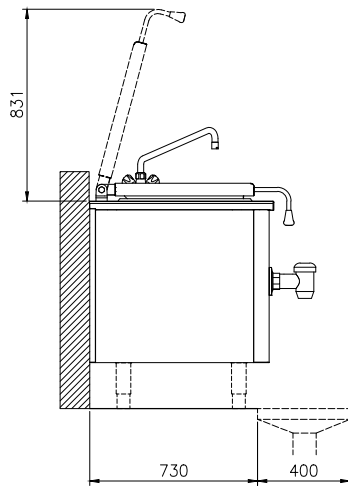

CWI = Cold Water inlet 1  
 EI = Electrical inlet (power)  
 HWI = Hot water inlet

Top

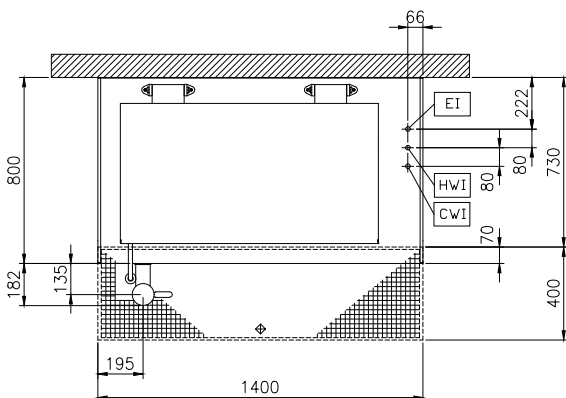

## Electric

Supply voltage:

586753 (PFEN17EAEM) 400 V/3N ph/50/60 Hz

Auxiliary:

0 kW

Total Watts:

20.6 kW

## Installation:

FS on concrete base; FS on feet; On base; Standing against wall

Type of installation:

## Key Information:

Configuration: Rectangular; Fixed

Working Temperature MIN: 50 °C

Working Temperature MAX: 250 °C

Vessel (rectangle) width: 1050 mm

Vessel (rectangle) height: 340 mm

Vessel (rectangle) depth: 550 mm

External dimensions, Width: 1400 mm

External dimensions, Depth: 800 mm

External dimensions, Height: 700 mm

Net weight: 160 kg

Net vessel useful capacity: 170 lt

Double jacketed lid: ✓

Heating type: Direct